

ECE276B: Planning & Learning in Robotics

Lecture 7: Search-Based Motion Planning

Nikolay Atanasov
natanasov@ucsd.edu

UC San Diego
JACOBS SCHOOL OF ENGINEERING
Electrical and Computer Engineering

Outline

Label Correcting Algorithms

Dijkstra's Algorithm

A* Algorithm

Jump Point Search

Motion Planning as Deterministic Shortest Path

- ▶ Construct a graph (via cell decomposition, skeletonization, as a lattice, etc.) and search it for a least-cost path
- ▶ **Assumption:** there are no negative cycles in the graph, i.e., $J^{i_1:q} \geq 0$ for all $i_1:q \in \mathcal{P}_{i,i}$ and all $i \in \mathcal{V}$
- ▶ The deterministic shortest path problem can be solved via:
 - ▶ **Dynamic Programming:** computes shortest paths from *all* nodes to the goal
 - ▶ **Forward Dynamic Programming:** computes shortest paths from the start to *all* nodes
 - ▶ **Label correcting methods:** visit only promising nodes
- ▶ **Key ideas** of label correcting methods:
 - ▶ **Label g_i :** lowest cost discovered so far from s to node $i \in \mathcal{V}$
 - ▶ **Label correction:** each time g_i is reduced, the labels g_j of the **children** of i can be corrected: $g_j = g_i + c_{ij}$
 - ▶ **OPEN:** set of nodes that can potentially be part of the shortest path to τ

Label Correcting Algorithm

Algorithm Label Correcting Algorithm

```
1: OPEN  $\leftarrow \{s\}$ ,  $g_s = 0$ ,  $g_i = \infty$  for all  $i \in \mathcal{V} \setminus \{s\}$ 
2: while OPEN is not empty do
3:   Remove  $i$  from OPEN
4:   for  $j \in \text{Children}(i)$  do
5:     if  $(g_i + c_{ij}) < g_j$  and  $(g_i + c_{ij}) < g_\tau$  then            $\triangleright$  Only when  $c_{ij} \geq 0$  for all  $i, j \in \mathcal{V}$ 
6:        $g_j \leftarrow (g_i + c_{ij})$ 
7:       Parent( $j$ )  $\leftarrow i$ 
8:       if  $j \neq \tau$  then
9:         OPEN  $\leftarrow$  OPEN  $\cup \{j\}$ 
```

Theorem

If there exists at least one finite cost path from s to τ , then the Label Correcting (LC) algorithm terminates with $g_\tau = \mathbf{dist}(s, \tau)$, the shortest path length from s to τ . Otherwise, the LC algorithm terminates with $g_\tau = \infty$.

Label Correcting Algorithm

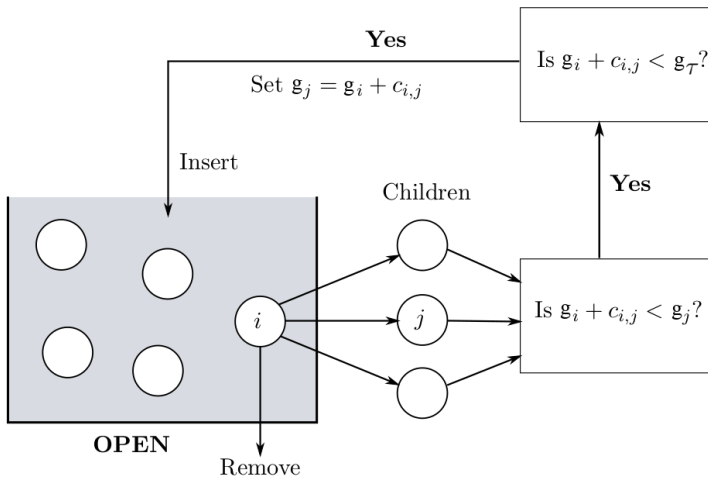

Label Correcting Algorithm

- Label correcting algorithms update the labels (g -values) of relevant states in OPEN until they satisfy the Bellman equation in dynamic programming:

$$g_i = \min_{j \in \text{Parents}(i)} g_j + c_{ji}$$

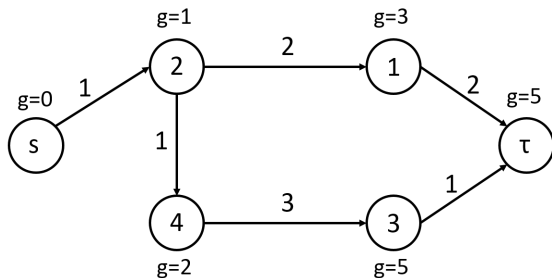

- Path recovery:** once correct g -values are available, the least-cost path i_q^*, \dots, i_1^* is a greedy path computed starting from $i_1^* = \tau$ and backtracking:

$$i_{k+1}^* = \arg \min_{j \in \text{Parents}(i_k^*)} g_j + c_{j, i_k^*} \quad \text{until } i_{k+1}^* = s$$

Outline

Label Correcting Algorithms

Dijkstra's Algorithm

A* Algorithm

Jump Point Search

Dijkstra's Algorithm

- ▶ **Best-first search:** label correcting algorithm that removes nodes with minimum label g_i from OPEN (implemented as a **priority queue**):

$$i \in \arg \min_{j \in OPEN} g_j$$

- ▶ **Node expansion:** once removed from OPEN, node i is expanded by correcting the labels of its children $j \in Children(i)$
- ▶ **Upon termination:** g_i equals the true cost $\mathbf{dist}(s, i)$ of the shortest path from s to i for all expanded nodes

Dijkstra's Algorithm Properties

- ▶ When $c_{ij} \geq 0$
 - ▶ The algorithm expands nodes in the order of distance from s
 - ▶ Each node is expanded at most once
 - ▶ If $i \in OPEN$, its label g_i may decrease as we discover new paths to i
 - ▶ $g_i \geq \mathbf{dist}(s, i)$ always with equality once i is expanded
 - ▶ Once we remove i from OPEN, its label g_i can no longer change because all other nodes in OPEN have higher g -values. We cannot hope to find a shorter path to i passing through a node in OPEN.
 - ▶ OPEN is the “search frontier” and separates expanded from unexplored nodes. Hence, once a node is removed from OPEN, we cannot hope to find a better path to it. **A node will enter OPEN at most once.**
 - ▶ Once τ is removed from OPEN, we cannot discover a shorter path to τ : **Done!**
- ▶ When c_{ij} may be negative but there are no negative cycles and $\mathbf{dist}(i, \tau) \geq 0$ for all $i \in \mathcal{V}$
 - ▶ Nodes may be expanded more than once, i.e., may re-enter OPEN
 - ▶ No guarantee that $g_i \geq \mathbf{dist}(s, i)$ throughout the execution
 - ▶ The algorithm terminates with $g_i = \mathbf{dist}(s, i)$

OPEN is the Search Frontier

- ▶ Dijkstra's algorithm may be thought of as fluid flow starting from s and expanding out
- ▶ The costs c_{ij} specify the time for the fluid to traverse edge $i \rightarrow j$
- ▶ When the fluid arrives at a node i , we update the ETA g_j of its neighbors j
- ▶ Some ETA estimates may be too large since the fluid may find shortcuts

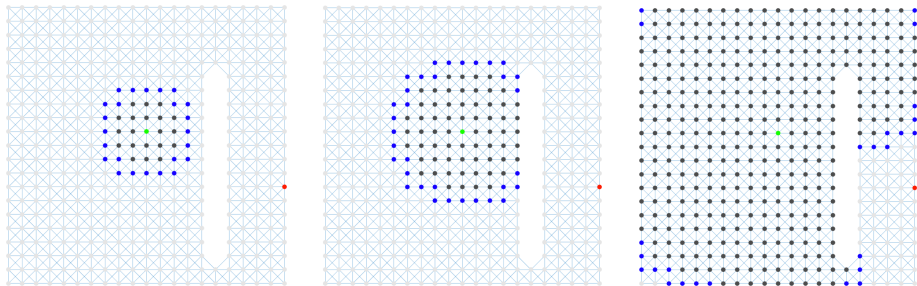

- ▶ The order of node expansions in Dijkstra only considers g_i , the cost from s to i but does **not** consider how costly the path from i to τ might be. Can this be estimated and used to improve the search?

Outline

Label Correcting Algorithms

Dijkstra's Algorithm

A* Algorithm

Jump Point Search

A* Algorithm

- ▶ The **A* algorithm** is a modification of the label correcting algorithm with $c_{ij} \geq 0$ in which the requirement for admission to OPEN is strengthened:

$$\text{from } g_i + c_{ij} < g_\tau \quad \text{to } g_i + c_{ij} + h_j < g_\tau$$

where h_j is a non-negative lower bound on the optimal cost-to-go from node j to τ known as a **heuristic function**:

$$0 \leq h_j \leq \mathbf{dist}(j, \tau)$$

- ▶ The more stringent criterion for admission to OPEN can reduce the number of iterations required by the label correcting algorithm to find an optimal path
- ▶ The more accurately h_j estimates $\mathbf{dist}(j, \tau)$, the more efficient the A* algorithm becomes!

Heuristic Function

- ▶ A heuristic function h_i is constructed using special knowledge about the problem

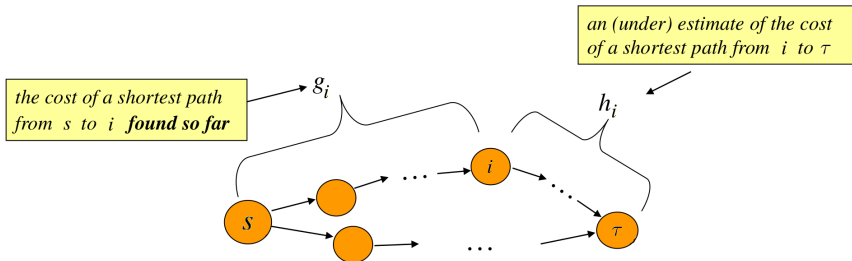

Heuristic Function

- ▶ A heuristic must be admissible for the A* algorithm to work correctly
- ▶ A heuristic may be consistent to make the A* algorithm more efficient
- ▶ **Admissible:** $h_i \leq \text{dist}(i, \tau)$ for all $i \in \mathcal{V}$
- ▶ **Consistent:** $h_\tau = 0$ and $h_i \leq c_{ij} + h_j$ for all $i \neq \tau$ and $j \in \text{Children}(i)$
 - ▶ h satisfies the **triangle inequality**, which implies it is also admissible
 - ▶ If $h^{(1)}$ and $h^{(2)}$ are consistent, then $h := \max\{h^{(1)}, h^{(2)}\}$ is consistent
 - ▶ If $h^{(1)}$ and $h^{(2)}$ are consistent, then $h := h^{(1)} + h^{(2)}$ is ϵ -consistent ($\epsilon = 2$)
- ▶ **ϵ -Consistent:** $h_\tau = 0$ and $h_i \leq \epsilon c_{ij} + h_j$ for all $i \neq \tau$, $j \in \text{Children}(i)$, and $\epsilon \geq 1$
- ▶ A heuristic function $h^{(2)}$ **dominates** $h^{(1)}$ if both are admissible and $h_i^{(2)} \geq h_i^{(1)}$ for every node $i \in \mathcal{V}$
 - ▶ Extreme cases: $h_i = 0$ and $h_i = \text{dist}(i, \tau)$

Examples of Heuristic Functions

- ▶ Grid-based planning: let $\mathbf{x}_i \in \mathbb{R}^d$ be the position of node i
 - ▶ Euclidean distance: $h_i := \|\mathbf{x}_\tau - \mathbf{x}_i\|_2$
 - ▶ Manhattan distance: $h_i := \|\mathbf{x}_\tau - \mathbf{x}_i\|_1 := \sum_k |x_{\tau,k} - x_{i,k}|$
 - ▶ Diagonal distance: $h_i := \|\mathbf{x}_\tau - \mathbf{x}_i\|_\infty := \max_k |x_{\tau,k} - x_{i,k}|$
 - ▶ Octile distance: $h_i := \max_k |x_{\tau,k} - x_{i,k}| + (\sqrt{d} - 1) \min_k |x_{\tau,k} - x_{i,k}|$
- ▶ Robot arm planning:
 - ▶ End-effector distance: run 2-D Dijkstra for the end effector and use it as a heuristic in the n -dimensional search for a joint angle path

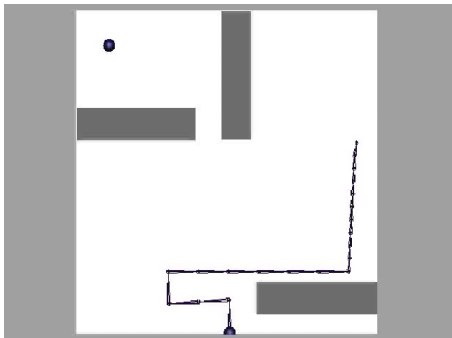
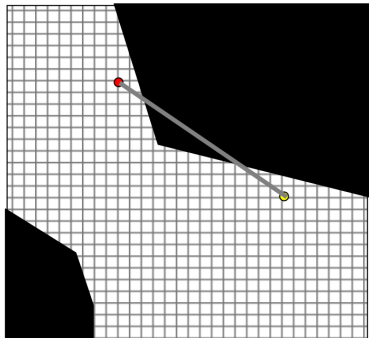

A* Algorithm with an ϵ -consistent Heuristic

Algorithm Weighted A* Algorithm

```
1: OPEN  $\leftarrow$  {s}, CLOSED  $\leftarrow$  {},  $\epsilon \geq 1$ 
2:  $g_s = 0$ ,  $g_i = \infty$  for all  $i \in \mathcal{V} \setminus \{s\}$ 
3: while  $\tau \notin$  CLOSED do
4:   Remove  $i$  with smallest  $f_i := g_i + \epsilon h_i$  from OPEN
5:   Insert  $i$  into CLOSED
6:   for  $j \in$  Children( $i$ ) and  $j \notin$  CLOSED do
7:     if  $g_j > (g_i + c_{ij})$  then
8:        $g_j \leftarrow (g_i + c_{ij})$ 
9:       Parent( $j$ )  $\leftarrow i$ 
10:    if  $j \in$  OPEN then
11:      Update priority of  $j$ 
12:    else
13:      OPEN  $\leftarrow$  OPEN  $\cup$  { $j$ }
```

$\triangleright \tau$ not expanded yet
 \triangleright means $g_i + \epsilon h_i < g_\tau$

expand state i :
 \circ try to decrease g_j using path from s to i

- ▶ There are 3 kinds of states:
 - ▶ **CLOSED**: set of states that have already been expanded
 - ▶ **OPEN**: set of candidates for expansion (frontier)
 - ▶ Unexplored: the rest of the states

Example: A* Algorithm

- ▶ $OPEN = \{s\}$
- ▶ $CLOSED = \{\}$
- ▶ Next to expand: s

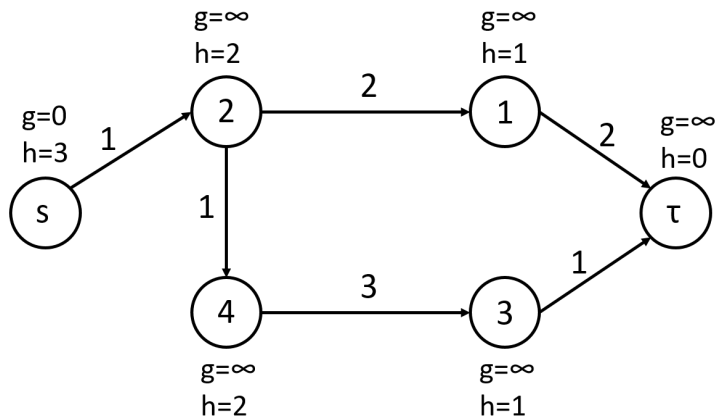

Example: A* Algorithm

- ▶ $OPEN = \{s\}$
- ▶ $CLOSED = \{\}$
- ▶ Next to expand: s

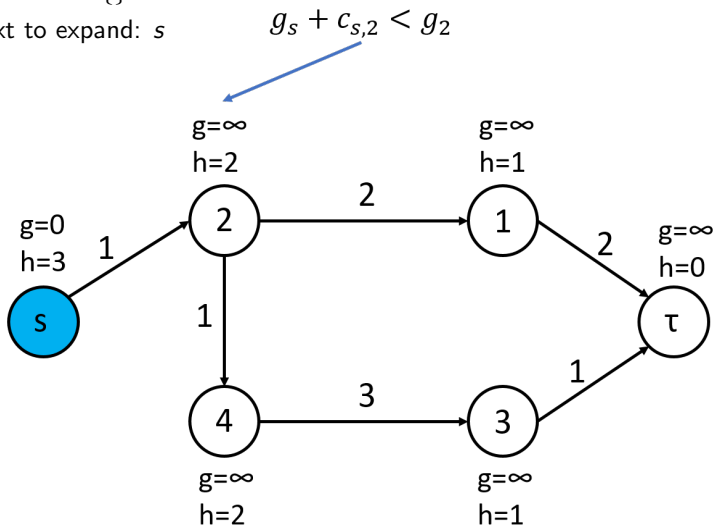

Example: A* Algorithm

- ▶ $OPEN = \{2\}$
- ▶ $CLOSED = \{s\}$
- ▶ Next to expand: 2

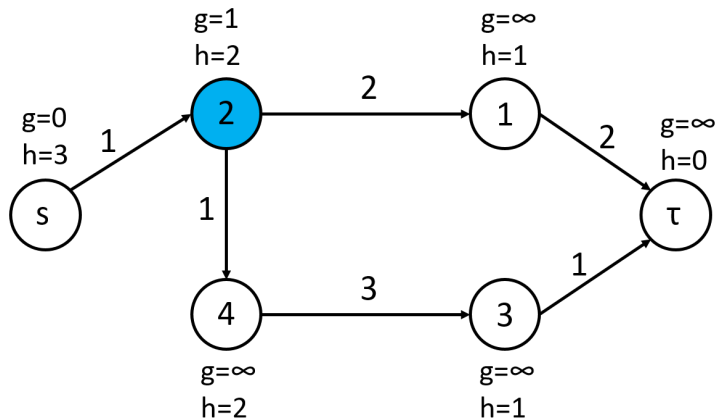

Example: A* Algorithm

- ▶ $OPEN = \{1, 4\}$
- ▶ $CLOSED = \{s, 2\}$
- ▶ Next to expand: 1

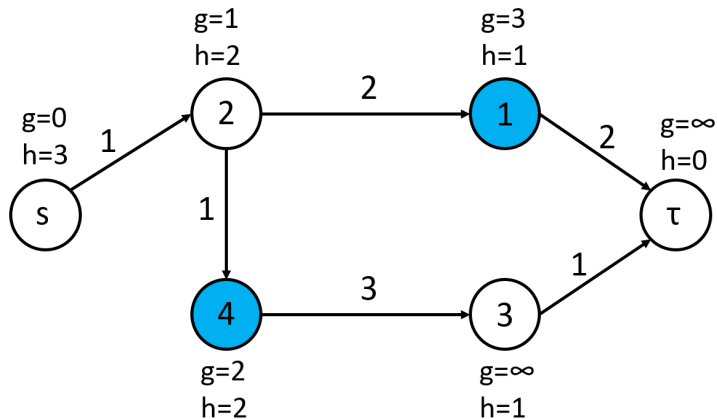

Example: A* Algorithm

- ▶ $OPEN = \{4, \tau\}$
- ▶ $CLOSED = \{s, 2, 1\}$
- ▶ Next to expand: 4

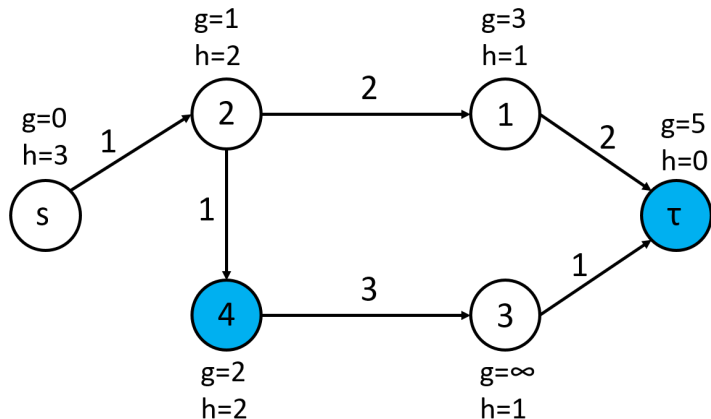

Example: A* Algorithm

- ▶ $OPEN = \{3, \tau\}$
- ▶ $CLOSED = \{s, 2, 1, 4\}$
- ▶ Next to expand: τ

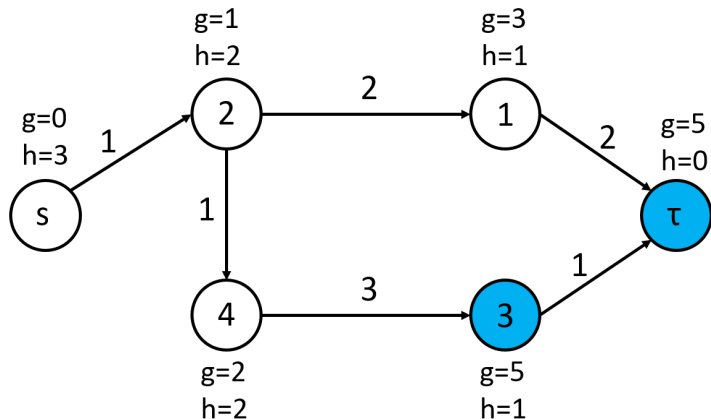

Example: A* Algorithm

- ▶ $OPEN = \{3\}$
- ▶ $CLOSED = \{s, 2, 1, 4, \tau\}$
- ▶ Done

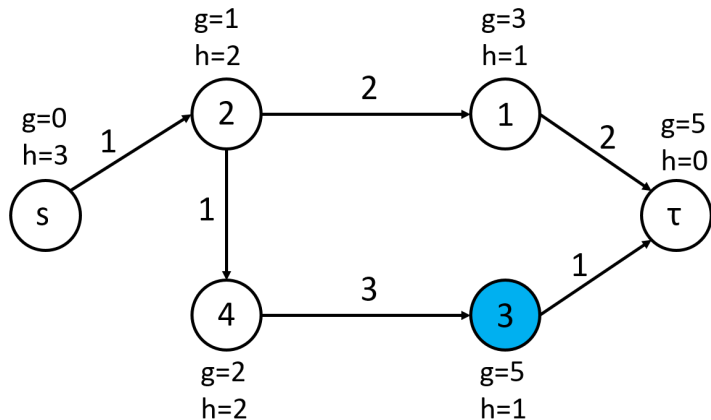

Theoretical Properties of A*

Theorem: Finite Termination

A* terminates in a finite number of iterations if \mathcal{V} is finite or if $c_{ij} \geq \delta > 0$ for $i, j \in \mathcal{V}$ and the degree of each node $i \in \mathcal{V}$ is finite.

Lemma: Consistent Heuristic Implies Correct Labels

If $c_{ij} \geq 0$ for $i, j \in \mathcal{V}$ and A* uses a consistent heuristic, then:

- ▶ g_i equals the least-cost from s to i for every expanded state $i \in CLOSED$
- ▶ g_i is an upper bound on the least-cost from s to i for every $i \notin CLOSED$

Proof of Lemma

► Proceed by induction:

1. Assume all previously expanded states (in CLOSED) have correct g -values
2. Let the next state to expand be i with $f_i := g_i + h_i \leq f_j$ for all $j \in OPEN$
3. Suppose that g_i is incorrect, i.e., $g_i > \mathbf{dist}(s, i)$
4. Then, there must exist at least one state j on an optimal path from s to i such that $j \in OPEN$ but $j \notin CLOSED$ so that $f_j \geq f_i$
5. Let j be the shallowest OPEN node on the optimal path from s to i , i.e., $\exists k \in CLOSED$ such that $g_j = g_k + c_{kj} = \mathbf{dist}(s, j)$
6. However, this leads to a contradiction:

$$f_i = g_i + h_i > \mathbf{dist}(s, i) + h_i = g_j + \mathbf{dist}(j, i) + h_j \stackrel{h \text{ is consistent}}{\geq} g_j + h_j = f_j$$

Theoretical Properties of A*

Theorem: Optimality

- ▶ If A* uses a consistent heuristic, then it is guaranteed to return an optimal path to τ (and, in fact, to every expanded node)
- ▶ If A* uses an admissible but inconsistent heuristic, then it is guaranteed to return an optimal path as long as closed states are re-opened (i.e., remove $j \notin \text{CLOSED}$ on Line 6 of the A* algorithm on Slide 16)
- ▶ If A* uses an ϵ -consistent heuristic, then it is guaranteed to return an ϵ -suboptimal path with cost $\mathbf{dist}(s, \tau) \leq g_\tau \leq \epsilon \mathbf{dist}(s, \tau)$ for $\epsilon \geq 1$

Theorem: Efficiency

A* performs the minimal number of state expansions to guarantee optimality

Effect of the Heuristic Function

- ▶ f_i is an estimate of the cost of a least cost path from s to τ via i

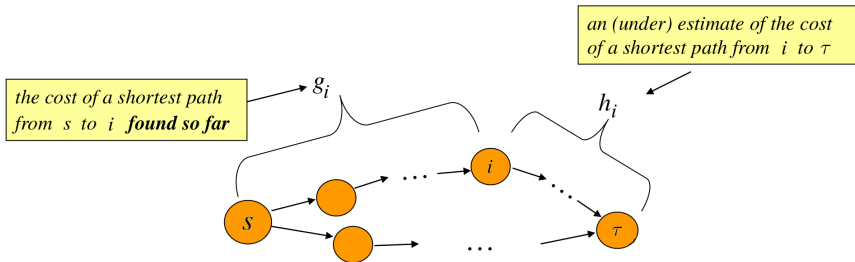

- ▶ **Dijkstra**: expands states in the order of $f_i = g_i$
- ▶ **A***: expands states in the order of $f_i = g_i + h_i$
 - ▶ all nodes with $f_i < \mathbf{dist}(s, \tau)$ are expanded
 - ▶ some nodes with $f_i = \mathbf{dist}(s, \tau)$ are expanded
 - ▶ no nodes with $f_i > \mathbf{dist}(s, \tau)$ are expanded
- ▶ **Weighted A***: expands states in the order of $f_i = g_i + \epsilon h_i$ with $\epsilon > 1$, i.e., biased towards states closer to the goal

Effect of the Heuristic Function: Dijkstra

- **Dijkstra:** expands states in the order of $f_i = g_i$

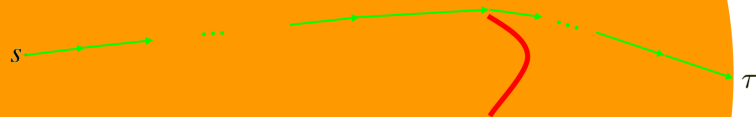

Effect of the Heuristic Function: A*

- ▶ **A***: expands states in the order of $f_i = g_i + h_i$
- ▶ The closer h_i is to **dist**(i, τ), the fewer expansions needed (fast search)
- ▶ The closer h_i is to 0, the more expansions needed (slow search)

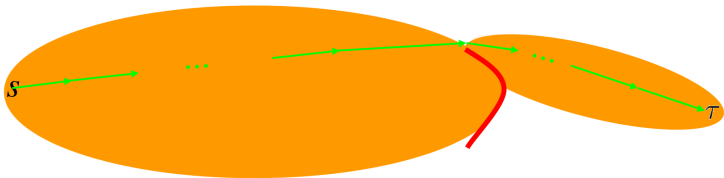

Effect of the Heuristic Function: Weighted A*

- ▶ **Weighted A***: expands states in the order of $f_i = g_i + \epsilon h_i$ with $\epsilon > 1$, i.e., biased towards states closer to the goal
- ▶ Weighted A* is ϵ -suboptimal ($g_\tau \leq \epsilon \mathbf{dist}(s, \tau)$) but trades optimality for speed. It is orders of magnitude faster than A* in many domains.
- ▶ The key to finding solutions fast is to have a heuristic function with shallow local minima!
- ▶ Is weighted A* guaranteed to expand no more states than A*?

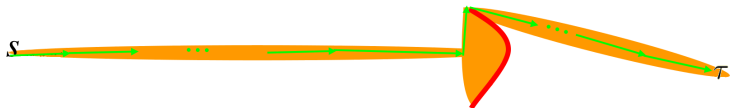

Implementation Details

- ▶ **Graph**: a **hashmap** data structure (stores key-value pairs) that maps node i to its properties: label g_i , heuristic h_i , parent, etc.
 - ▶ e.g., `std::unordered_map` in C++ or `dictionary` in Python
- ▶ **Depth-first search**: last-in, first-out (LIFO): *OPEN* is a **stack**
 - ▶ e.g., `std::stack` in C++ or `collections.deque` in Python
- ▶ **Breath-first search**: first-in, first-out (FIFO): *OPEN* is a **queue**
 - ▶ e.g., `std::queue` in C++ or `collections.deque` in Python
- ▶ **Dijkstra and A* search**: *OPEN* is a **priority queue** based on f_i
 - ▶ e.g., `boost::heap::d_ary_heap` in C++ or `pqdict` in Python

Time Complexity

- ▶ **Graph:** number of nodes $|\mathcal{V}|$, number of edges $|\mathcal{E}|$, maximum node degree Δ (number of outgoing edges)
- ▶ **Dynamic Programming:** $O(|\mathcal{V}|^3)$:
 - ▶ $|\mathcal{V}| \times |\mathcal{V}|$ entries in the table
 - ▶ Each entry requires Δ comparisons and in the worst case $\Delta = O(|\mathcal{V}|)$
- ▶ **Dijkstra and A*:** $O(\text{makequeue} + \text{pop} \times |\mathcal{V}| + \text{update} \times |\mathcal{E}|)$
 - ▶ Array and make_heap, e.g., `std::priority_queue` in C++:
 $O(|\mathcal{V}|) + O(|\mathcal{V}|)|\mathcal{V}| + O(1)|\mathcal{E}| = O(|\mathcal{V}|^2)$
 - ▶ Binary heap, e.g., `boost::heap::d_ary_heap` in C++:
 $O(|\mathcal{V}|) + O(\log |\mathcal{V}|)|\mathcal{V}| + O(\log |\mathcal{V}|)|\mathcal{E}| = O((|\mathcal{E}| + |\mathcal{V}|) \log |\mathcal{V}|)$
 - ▶ Fibonacci heap, e.g., `boost::heap::fibonacci_heap` in C++:
 $O(|\mathcal{V}|) + O(\log |\mathcal{V}|)|\mathcal{V}| + O(1)|\mathcal{E}| = O(|\mathcal{E}| + |\mathcal{V}| \log |\mathcal{V}|)$

| | Sparse graph: $ \mathcal{E} = O(\mathcal{V})$ | Dense graph: $ \mathcal{E} = O(\mathcal{V} ^2)$ |
|----------------|---------------------------------------------------------|----------------------------------------------------------|
| Array | $O(\mathcal{V} ^2)$ | $O(\mathcal{V} ^2)$ |
| Binary heap | $O(\mathcal{V} \log \mathcal{V})$ | $O(\mathcal{V} ^2 \log \mathcal{V})$ |
| Fibonacci heap | $O(\mathcal{V} \log \mathcal{V})$ | $O(\mathcal{V} ^2)$ |

Memory Complexity

- ▶ A* does provably minimum number of expansions, $O(|V|)$, to find the optimal solution but this might require an infeasible amount of memory
- ▶ The memory requirements of weighted A* are often but not always better
- ▶ **Depth-first search** (without marking expanded states): explore one possible path at a time and keep only the best path discovered so far in memory:
 - ▶ Complete and optimal (assuming a finite graph)
 - ▶ Memory: $O(\Delta m)$, where Δ - max branching factor, m - max pathlength
 - ▶ Time: $O(\Delta^m)$, since it will repeatedly re-expand states
- ▶ Example: 4-connected 40 by 40 grid with s at the center of the grid
 - ▶ A* expands up to 800 states
 - ▶ Depth-first search may expand over $4^{20} > 10^{12}$ states

- ▶ What if the goal is only a few steps away in a huge state space?
- ▶ **Iterative Deepening A***
 1. Set $f_{max} = 1$ (or some other small value)
 2. Run DFS that expands only states with $f \leq f_{max}$
 3. If DFS returns a path to the goal, **Done!**
 4. Otherwise $f_{max} = f_{max} + 1$ (or larger increment) and go to step 2
- ▶ Properties of IDA*
 - ▶ Complete and optimal in any graph with positive costs
 - ▶ Memory: $O(\Delta m^*)$, where Δ - max. branching factor, m^* - length of optimal path
 - ▶ Time: $O(k\Delta^{m^*})$, where k is the number of times depth-first search is called

Outline

Label Correcting Algorithms

Dijkstra's Algorithm

A* Algorithm

Jump Point Search

Jump Point Search

- ▶ In a large open space, there are many equal length shortest paths
- ▶ A* adds a node's immediate neighbors to the OPEN priority queue, only to pop them soon after
- ▶ What if we could look ahead and skip nodes that are not valuable, e.g., lead to symmetric paths?
- ▶ **Assumption:** undirected uniform-cost grid, i.e., the same move costs the same amount in every node i
- ▶ 2-D case:
 - ▶ each node has ≤ 8 neighbors
 - ▶ straight moves cost 1
 - ▶ diagonal moves cost $\sqrt{2}$

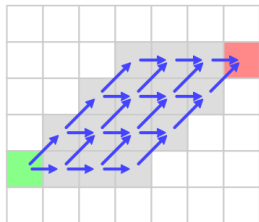

Straight Moves

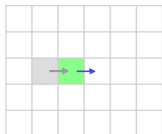

Consider horizontal/vertical movement from node i . We can ignore the node we are coming from (parent $p(i)$) since we already visited it

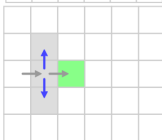

We can assume the two nodes diagonally behind us have been reached via $p(i)$ since those are shorter paths than going through i

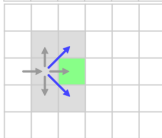

We can assume that the nodes above and below have also been reached via diagonal moves from $p(i)$, which cost $\sqrt{2}$ rather than going through i for a cost of 2

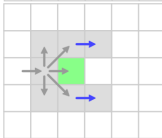

The nodes diagonally in front of us can be reached via the neighbors above and below

Forced Neighbors for Straight Moves

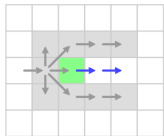

This leaves only a single **natural neighbor** to consider and that is the main idea – as long as the way is clear we can **jump** ahead to the right without adding any nodes to OPEN.

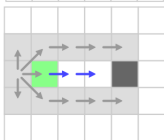

If the way is blocked as we jump to the right, we can safely disregard the entire jump because the paths above and below will be handled via other nodes.

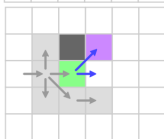

But what happens if one of these neighbors that we assume will cover other paths is blocked? We are **forced** to consider the node that would have otherwise been considered by the blocked path. Such a neighbor is called a **forced neighbor**. When we reach a node with a forced neighbor, we stop jumping right and add the node to the OPEN list for further examination.

Diagonal Moves

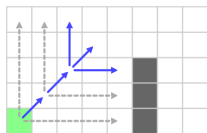
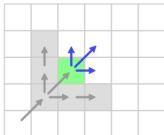

Consider diagonal movement from node i . As before, we can ignore the parent $p(i)$ since we already visited it. We can also ignore the left and below neighbors since they can be reached optimally from $p(i)$ via a straight move.

The nodes up and to the left and down and to the right can also be reached more optimally via the neighbors to the left and below.

This leaves three **natural neighbors**: two above and to the right, and one diagonally in the original direction of travel.

Two of the natural neighbors require straight moves and since we already know how to jump straight we can look there first for forced neighbors. If neither finds any, we move one more step diagonally and repeat.

Forced Neighbors for Diagonal Moves

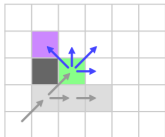

Similar to forced neighbors during straight movement, when an obstacle is present to our left or below, then the neighbors diagonally up-and-left and down-and-right cannot be reached in any other way but through i . These are **forced neighbors** for diagonal moves. When we reach a node with a forced neighbor, we stop jumping diagonally and add the node to OPEN for further examination.

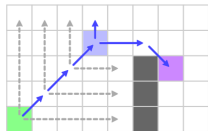

The straight-line jumps initiated from the two natural neighbors might also reach a forced neighbor. In that case, we also need to add the current node i to the OPEN set and continue with the next A* iteration.

Formal Definitions

- ▶ Let i be the current node under evaluation and $p(i)$ be its parent
- ▶ **Natural neighbor**: a node $j \in \text{Neib}(i)$ is a natural neighbor if
 - ▶ **(Straight Move)**: $c_{p(i),i} + c_{i,j} < c_{p(i),k} + c_{k,j}$ for all $k \in \text{Neib}(i)$, including $k = j$ in which case $c_{j,j} = 0$. In other words, j is a natural neighbor of i if the shortest path from $p(i)$ to j has to go through i .
 - ▶ **(Diagonal Move)**: $c_{p(i),i} + c_{i,j} \leq c_{p(i),k} + c_{k,j}$ for all $k \in \text{Neib}(i)$, including $k = j$ in which case $c_{j,j} = 0$. In other words, j is a natural neighbor of i if a shortest path from $p(i)$ to j has to go through i .
- ▶ **Forced neighbor**: a node $j \in \text{Neib}(i)$ is a forced neighbor if both:
 1. j is not a natural neighbor of i
 2. $c_{p(i),k} + c_{k,j} > c_{p(i),i} + c_{i,j}$ for all $k \in \text{Neib}(i)$
- ▶ **Jump point**: node j with coordinates x_j is a **jump point** from node i in direction d , if x_j minimizes $\lambda \in \mathbb{N}$ such that $x_j = x_i + \lambda d$ and one of the following holds:
 1. Node j is the goal node τ
 2. Node j has at least one forced neighbor
 3. $\|d\|_1 = 2$ (diagonal move) and $\exists k \in \mathcal{V}$ which lies $\lambda_i \in \mathbb{N}$ steps in a straight direction $d_i \in \{d_1, d_2\}$, i.e., $x_k = x_j + \lambda_i d_i$, and k is a jump point from j by condition 1 or 2 above.

Putting It All Together

- ▶ We apply the A* algorithm as usual, except that when we are expanding a node i from the OPEN list we:
 1. Look at its parent $p(i)$ to determine the direction of travel.
 2. Jump as far as possible (straight first, then diagonally), skipping intermediate nodes using the simplifying rules until we encounter a jump point j
 3. We treat j as if it were an immediate child of i : try to decrease its g -value and then insert it into OPEN
- ▶ **Main takeaway:** accessing the contents of many points on a grid in a few iterations of A* is more efficient than maintaining a priority queue over many iterations of A*

2-D Jump Point Search

Algorithm 2-D Jump Point Search

```
1: function GETSUCCESSORS( $i, \tau$ )
2:   Successors( $i$ )  $\leftarrow \emptyset$ 
3:   Neighbors( $i$ )  $\leftarrow$  PRUNE( $i, \text{Neighbors}(i)$ )
4:   for all  $j \in \text{Neighbors}(i)$  do
5:      $j \leftarrow$  JUMP( $i, \text{direction}(i, j), \tau$ )
6:     add  $j$  to Successors( $i$ )
7:   return Successors( $i$ )
8:
9: function JUMP( $i, d, \tau$ )
10:   $j \leftarrow$  STEP( $i, d$ )
11:  if  $j$  is an obstacle or outside the grid then
12:    return null
13:  if  $j = \tau$  or  $\exists k \in \text{Neighbors}(j)$  such that  $k$  is forced then
14:    return  $j$ 
15:  if  $\|d\|_1 = 2$  (diagonal) then
16:    for  $k \in \{1, 2\}$  do
17:      if JUMP( $j, d_k, \tau$ ) is not null then
18:        return  $j$ 
19:  return JUMP( $j, d, \tau$ )
```

▷ Keep all neighbors of the start node s
▷ Keep only natural and forced neighbors

Example: 2-D JPS

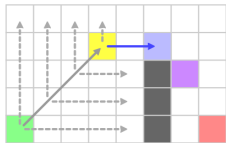

Starting from the green node in OPEN we jump horizontally, then vertically, then diagonally until a jump finds a node (blue) with a forced neighbor (purple). We add the yellow node to OPEN.

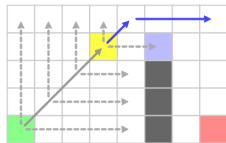

We expand the yellow node. Checking diagonally leads to the edge of the map so no new jump points are added. The jump point (blue) is added to the OPEN list.

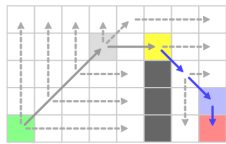

We expand the yellow node from OPEN. Since we were moving diagonally, we first explore the horizontal (leads to map edge) and vertical (blocked) directions and then jump diagonally.

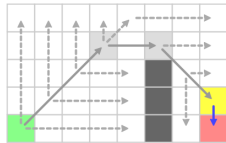

We encounter a node with a forced neighbor (the goal) and add it to OPEN. Expanding this last node reaches the goal.

2-D JPS Pruning Rules and Optimality

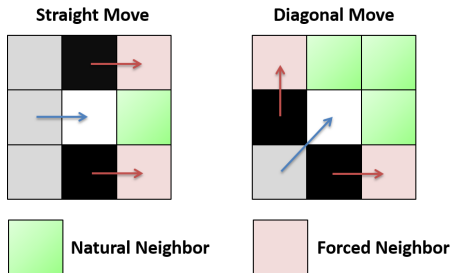

Theorem: Optimality of JPS (Harabor and Grastien, AAI 2011)

Jump point search in a 2-D undirected uniform-cost grid returns the cost of an optimal path from s to τ if a feasible path exists and ∞ otherwise.

- ▶ D. Harabor and A. Grastien, "Online Graph Pruning for Pathfinding on Grid Maps," AAI, 2011

3-D JPS Pruning Rules

